



DIVERSITECH
Air Pollution Solutions

Operation & Maintenance Manual

MONSOON WET DOWNDRAFT TABLES



MDD-MINI



MDD-3X4



MDD-3X6



MDD-3X8

READ AND SAVE THESE INSTRUCTIONS

Visit our Website for more information on this product

www.diversitech.ca

1200 55th Avenue, Montreal, Quebec H8T 3J8
Tel: 1.800.361.3733 | Fax: 1.514.631.9480 | info@diversitech.ca

Table of Contents

SECTION 1 – SAFETY PRECAUTIONS OF FUME & DUST EXTRACTION/COLLECTION	3
1.1 Symbols	3
1.2 User Responsibility	3
1.3 Dust Collection Hazards	3
SECTION 2 – SPECIFICATIONS	4
2.1 Diagram & Description	4
2.2 Specifications	4
2.3 Dimensions	4
SECTION 3 – SETUP / INSTALLATION	5
3.1 To Setup or Install Safely	5
3.2 Un-Packaging	5
3.3 Selecting a Location	5
3.4 Installation	5
3.5 Preparing Unit for Operation	5
SECTION 4 – OPERATION	6
4.1 To Operate Safely	6
4.2 Controls	6
4.3 Pre-Use Checklist	7
4.4 Principles of Operation.....	7
SECTION 5 – MAINTENANCE & TROUBLESHOOTING	8
5.1 To Maintain this Product Safely	8
5.2 Tools Required	8
5.3 Routine Maintenance Schedule	9
5.4 Troubleshooting Procedure	11
APPENDIX 1A – ELECTRICAL DIAGRAM MANUAL-WATER LEVEL.....	12
APPENDIX 1B – ELECTRICAL DIAGRAM AUTO-WATER LEVEL CONTROL SYSTEM.....	13
APPENDIX 2 – OPTIONAL AUTO WASH-DOWN SPRAY SYSTEM	15
APPENDIX 3 – MAINTENANCE RECORD	16
NOTES	17,18,19
Limited Equipment Warranty	Back Cover
Freight Claims	Back Cover
Return Material Policy	Back Cover

SECTION 1 - SAFETY PRECAUTIONS OF FUME & DUST EXTRACTION/COLLECTION



READ
BEFORE
USE

This manual contains specific cautionary statements related to worker safety. To protect yourself and others, read this manual thoroughly and follow as directed before use. Not all hazards of fume & dust control are listed in this manual, and no hazards related to welding, cutting, grinding, painting, deburring or other applications are listed. Consult a qualified safety professional.



DO
NOT
USE

Do not use this equipment:

- To collect smoke, fumes, liquid vapors, or aggressive fumes such as acids.
- If the power cord has been damaged or ground (third prong) removed.
- Without the proper water level in the basin.

1.1 Symbols

This manual uses several symbols to highlight specific hazards. Be familiar with these symbols and when you see them in this manual, read adjoining warning text to avoid the hazard.



WARNING!
DANGER!



ELECTRIC
SHOCK



MOVING
PARTS



HOT
PARTS

1.2 Users Responsibility

- Improper use can be hazardous.
- It is your responsibility to follow all applicable ANSI, OSHA, UL, CSA, National & Local Fire Codes, and other regulatory guidelines covering the safe use of equipment that extracts fumes, collects dusts, and exhausts filtered air either indoors or outdoors.
- Before use, inspect the unit for damage and verify it is working properly.
- Only qualified persons should install, operate, maintain, or repair this unit.
- Do not modify or repair the unit with parts or accessories not supplied by the manufacturer.
- Consult filter manufacturer's instructions for filter use and reuse, including instructions for cleaning.

1.3 Dust Collection Hazards

- Dusts from many metalwork, woodwork, food production, pharmaceutical, other material processing applications can be combustible.
- Combining dusts from of different materials can introduce additional hazards as chemical reactions can happen in the airstream or in the water basin. Consult a qualified person before mixing more than one base material in a wet dust collector.
- Do not use or install equipment where any potential for combustible fumes or dusts are present, until a qualified person has indicated it is safe to do so.
- Never use or install equipment where the potential for combustible fumes or dusts are present without a fire/explosion protection system.
- If you are unsure if the product you purchased is correct for your application, call Diversitech at 1-800-361-3733.

SECTION 2 - SPECIFICATIONS

2.1 Diagram & Description



MDD-MINI
23 gallon, 1200 CFM
Wet Downdraft Table



MDD-3X4
40 gallon, 3000 CFM
Wet Dust Collector



MDD-3X6
60 gallon, 5000 CFM
Wet Downdraft Table



MDD-3X8
80 gallon, 6500 CFM
Wet Downdraft Table

2.2 Specifications

Model	Water Fill System	Nominal Airflow (CFM)	Tank Capacity (Gallons)	Motor (H.P)	Power			Noise @5ft. (dB)	
					Phase (hz)	@230V (amps)	@460V (amps)		@575V (amps)
MDD-MINI	manual	1200	23	3.0	3P / 60Hz	9.6	4.8	3.9	75
MDD-3X4	auto	3000	40	5.0	3P / 60Hz	15.2	7.6	6.1	72
MDD-3X6	auto	5000	60	10.0	3P / 60Hz	28.0	14.0	11.0	78
MDD-3X8	auto	6500	60	15.0	3P / 60Hz	34.0	16.9	14.0	80

2.3 Dimensions

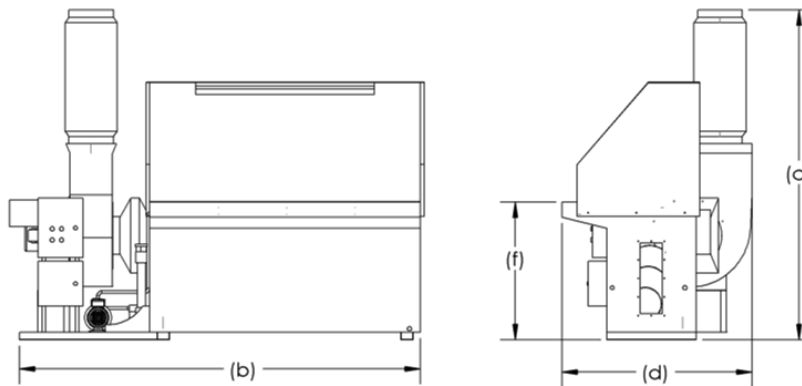

Model	Footprint (in.)			Net Weight (lbs.)	Work surface (in.)			Water	
	Width [b]	Height [C]	Length [d]		Width	Height [f]	Length	Supply (in.)	Drain (in.)
MDD-MINI	68	74	45	542	30	37	36	1/2 NPT	1 1/2" NPT
MDD-3X4	90	89	45	621	49	37	36	1/2 NPT	1 1/2" NPT
MDD-3X6	115	89	45	646	73	37	36	1/2 NPT	1 1/2" NPT
MDD-3X8	142	89	56	810	97	37	36	1/2 NPT	1 1/2" NPT

1. Water Level is marked on each unit.

SECTION 3 - SETUP / INSTALLATION

3.1 To Setup or Install Safely



- Do not place unit near flammables or combustible surface.
- Refer to **SECTION 2: Specifications**, to know the electrical requirements of the unit you are installing and ensure adequate input power that is properly sized, rated, and protected.
- This unit must be grounded for safe operation.

3.2 Un-Packaging

1. Immediately upon receiving the unit, carefully examine the carton for damage during transit.
2. Remove packing material.
3. Avoid tipping or inverting during handling.
4. The item serial number, model, and electrical ratings are listed on the nameplate. Record this information in the Maintenance Record provided in **APPENDIX 3: Maintenance Record**, or your own preventative maintenance system.

3.3 Selecting a Location

- Choose a location where the unit will be used, near the operator.
- Choose a location sufficiently close to a grounded power source.

3.4 Installation

- Connect ducts to air inlet, considering:
 - Duct diameter, length, and material type will effect performance.
 - Use smooth bore ducting wherever possible as flexible ducts can have up to three times more airflow resistance.
 - Inlet ducts should be full diameter, and changes in section or size should be gradual.
- Connect pipes to water supply and drain fittings (see **SECTION 2.1 Specifications**).
- Connect power as outlined in **APPENDIX 1A: Electrical Diagram [230/460/575v] 3-Phase Power**.
- Ensure that motor rotation is clockwise when looking top-down from unit.
- Fill the Collector's basin with water to the indicated water level.

3.5 Preparing Unit for Operation

- Before plugging unit in to an input power source, look at the manufacturer's label located on the exterior of the unit and ensure the source is correctly sized in terms of Voltage and Amperes.
- Prior to use in your application, turn the unit ON, and perform a function test. To do so:
 1. Turn switch to ON position
 2. LOOK: Is the unit level, stable, and that nothing is obstructing the extraction path. Is there adequate water in the basin.
 3. LISTEN: Does the motor and suction sound smooth and within expected volumes.
 4. FEEL: Place your hand on top of the unit and sense for unexpected vibration. Place your hand in front of the intake hood/surface and sense for expected level(s) of suction.
- Inform all potential users of this equipment where they may find and review this manual.

SECTION 4 - OPERATION BEFORE USE

4.1 To Operate Safely



- Read and understand **SECTION 1: Safety Precautions** and **SECTION 4: Operation before use**
- Read and understand all Material Safety Data Sheets and Manufacturer's instructions of all process materials, consumables, and equipment used in conjunction with this equipment.
- Keep away from all mechanical moving parts including motor, gears, and other pinch points.
- Do not use product without first confirming if a Spark Arrestor is required and installed for the type of dust, or fumes you are extracting and/or collection. If you are unsure, call a Diversitech representative at 1-800-361-3733.

4.2 Controls

Units with Manual Water-fill

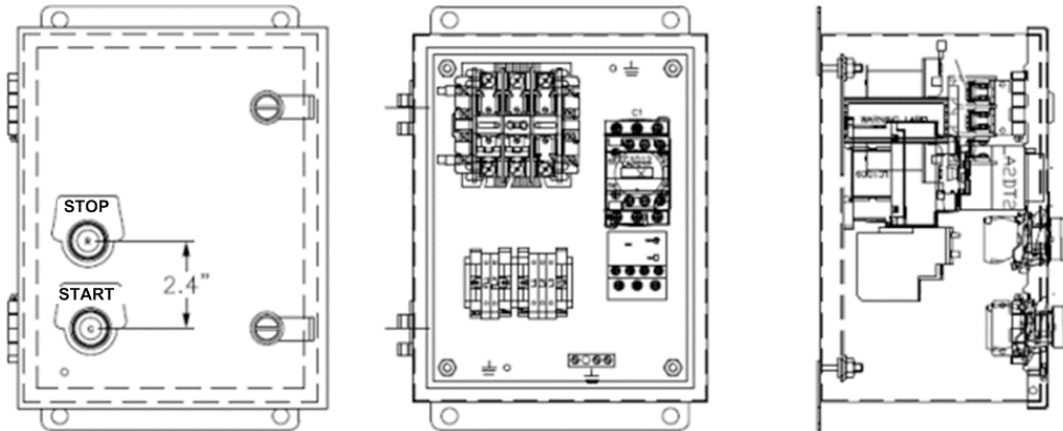

Units with Auto Water-fill Control System

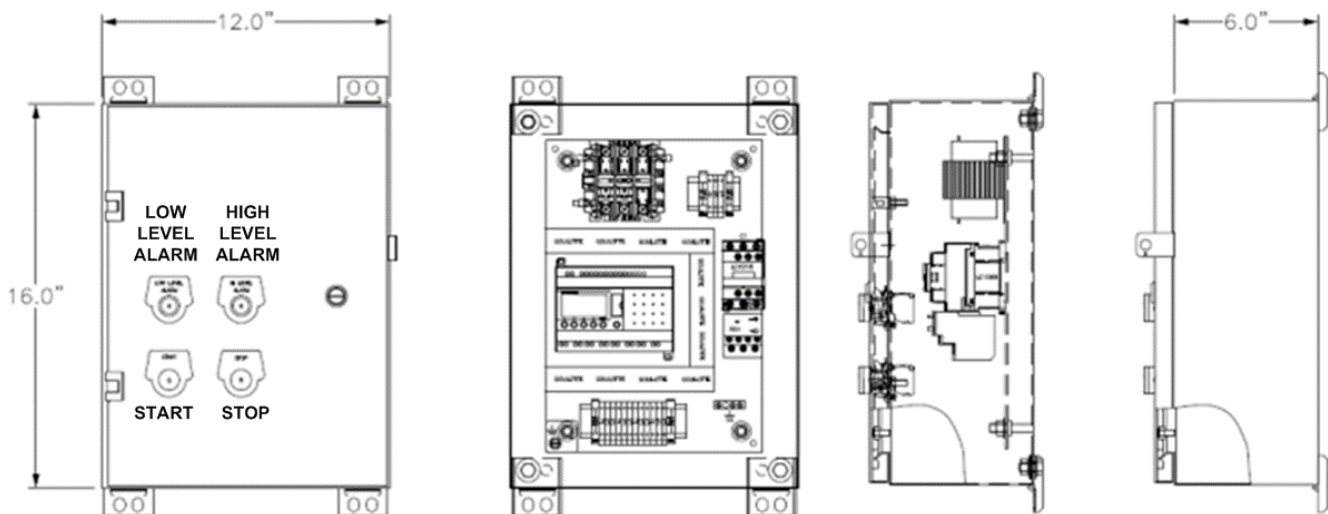

4.3 Pre-Use Checklist

- Before plugging unit in to an input power source, look at the manufacturer's label located on the exterior of the unit and ensure the source is correctly sized in terms of Voltage and Amperes.
- Prior to use in your application, turn the unit ON, and perform a function test. To do so:
 1. Turn switch to ON position
 2. LOOK: Is the unit level, stable, and that nothing is obstructing the extraction path. Is there adequate water in the basin.
 3. LISTEN: Does the motor and suction sound smooth and within expected volumes.
 4. FEEL: Place your hand on top of the unit and sense for unexpected vibration. Place your hand in front of the intake hood/surface and sense for expected level(s) of suction.
- Inform all potential users of this equipment where they may find and review this manual.

4.4 Principles of Operation

This product is designed to capture potentially combustible dust particulate from certain industrial applications using a wet filtration process. When operating, air and dust is drawn into the table, passes through internal baffling, into the wet filtration system, through a mist eliminating after-filter, and then finally exhausted out a top discharge. The agitation of water creates a humid environment within the collector, trapping the hazardous dusts, which will settle in the bottom of the basin.

This product consists of five basic components:

1. A cabinet for housing all components.
2. A motor blower assembly
3. Electrical assemblies
4. Collecting assemblies (filters pad and water)
5. Downdraft table

SECTION 5 - MAINTENANCE & TROUBLESHOOTING

5.1 To Maintain this Product Safely



- Read and understand **SECTION 1: Safety Precautions** and **SECTION 4: Operation before use**.
- Do not breathe the dust collected from product while changing/cleaning filters or performing maintenance on this product.



- Disconnect power before performing any maintenance on unit, including filter inspection. The input power to this unit is high voltage, and touching any live electrical parts can cause fatal shocks or severe burns. Do not touch live electrical parts.



- Keep away from all mechanical moving parts including motor, gears, and other pinch points while operating.



- Operating this unit causes some parts to heat to a point that will burn bare hands. Before maintenance allow parts to cool, or use proper tools and personal protection equipment during maintenance.

5.2 Tools Required



**EYE
PROTECTION**



RESPIRATOR



GLOVES





**WASTE
CONTAINER**



SLUDGE VAC

5.3 Routine Maintenance Schedule

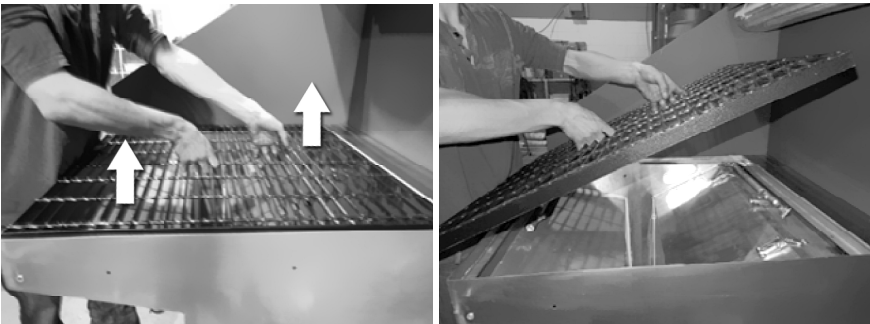
The manufacturer recommends the following routine maintenance based on light-duty use in normal operating conditions. Service more frequently if the unit is used severe conditions.

Frequency	Manual Reference
Pre-Use	4.3
<ul style="list-style-type: none">Perform pre-use inspection to ensure operating correctly.	
Daily Inspection	
<ul style="list-style-type: none">Inspect all equipment surfaces for dust buildup, and wipe down as needed.Inspect filter panels for dust buildup, and service as needed.Check Water Level, and fill the basin with water to the indicated water level if needed.Turn unit on, and check for moisture passing through the blower, by placing hand above exhaust stack. If excess moisture is detected, partially drain water from basin to indicated water level.	
Every (2) Weeks or 30 operating hours – Exchange Water	
<ol style="list-style-type: none">Remove the water using the drain outlet provided, considering:<ol style="list-style-type: none">Drained material should be kept away from any electrical equipment;Drained material may contain high concentrations of material waste, and depending on application, may require additional treatment, or special handling for disposal. Consult your local regulators.Remove scrubber tree as shown.	
a. Remove grating	
b. Remove scrubber tree	

3. Remove semi-solid build-up at bottom of basin, using a Diversitech Sludge Vac or similar equipment, considering:
 - a. Removed material may contain high concentrations of material waste, and depending on application, may require additional treatment, or special handling for disposal. Consult your local regulators.
4. Clean basin with pressure washer or plastic-bristle brush (no metallic brushes).
5. Turn machine on and allow the Auto-level Water Control System to fill the basin, or fill basin manually.

As Required – Replace Filter

1. Replace after-filter media when it appears torn or dirty.

Every (12) months Inspect Basic Components

1. Clean unreadable labels and exterior surfaces.
2. Wash cabinet internal assemblies with warm water mixed with mild detergent (Allow 12 hours to dry before use).
3. Inspect controls for loose wiring.
4. Examine motors for signs of unusual wear.

Optional – Auto Wash-down Spray Kit

Every (1) Week or 15 operating hours – Inspect Pre-filter & Spray Nozzles

1. Inspect the water pumps pre-filter screen, visible through transparent casing, and clean with warm water and mild detergent as required.
2. Turn Auto Wash-down Spray Pump on, and inspect nozzles for clogs. Clean nozzles as required.

5.4 Troubleshooting Procedure

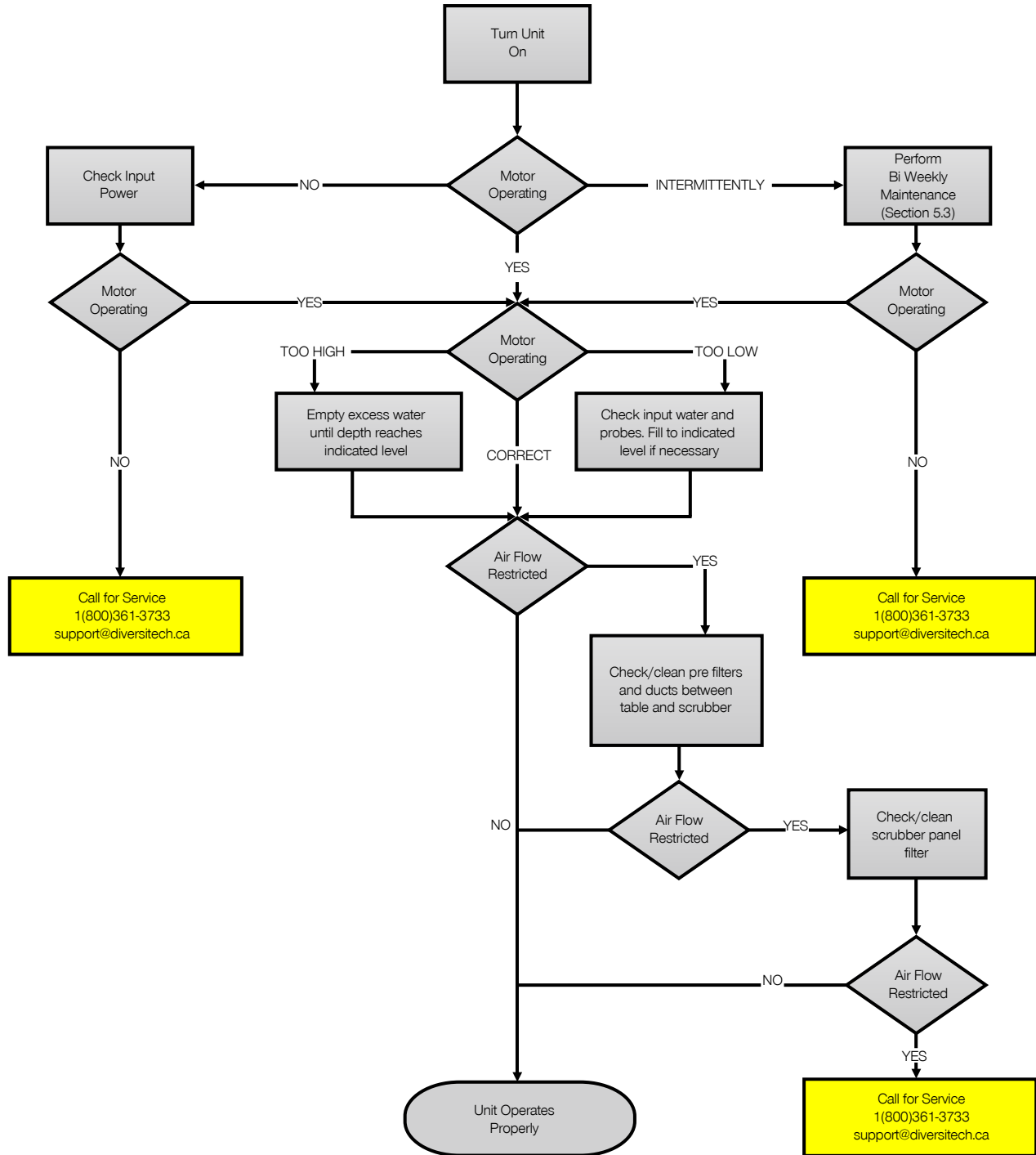

APPENDIX 1A - ELECTRICAL DIAGRAM MANUAL-WATER LEVEL

[230/460/575V] 3-Phase Power



**ELECTRIC
SHOCK
HAZARD**

Disconnect power before performing any maintenance on unit, including filter inspection. The input power to this unit is high voltage, and touching any live electrical parts can cause fatal shocks or severe burns. Do not touch live electrical parts.

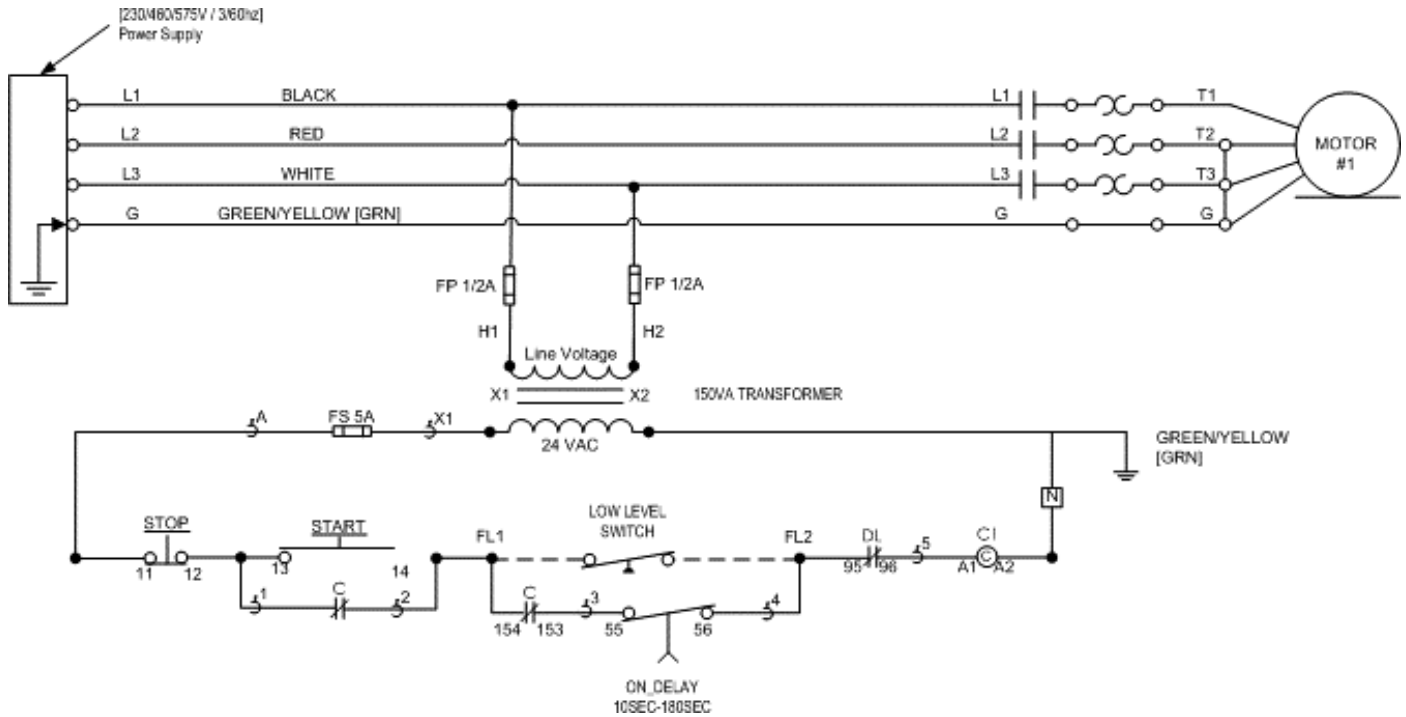

APPENDIX 1B - ELECTRICAL DIAGRAM AUTO-WATER LEVEL CONTROL SYSTEM

[230/460/575V] 3-Phase Power



**ELECTRIC
SHOCK
HAZARD**

Disconnect power before performing any maintenance on unit, including filter inspection. The input power to this unit is high voltage, and touching any live electrical parts can cause fatal shocks or severe burns. Do not touch live electrical parts.

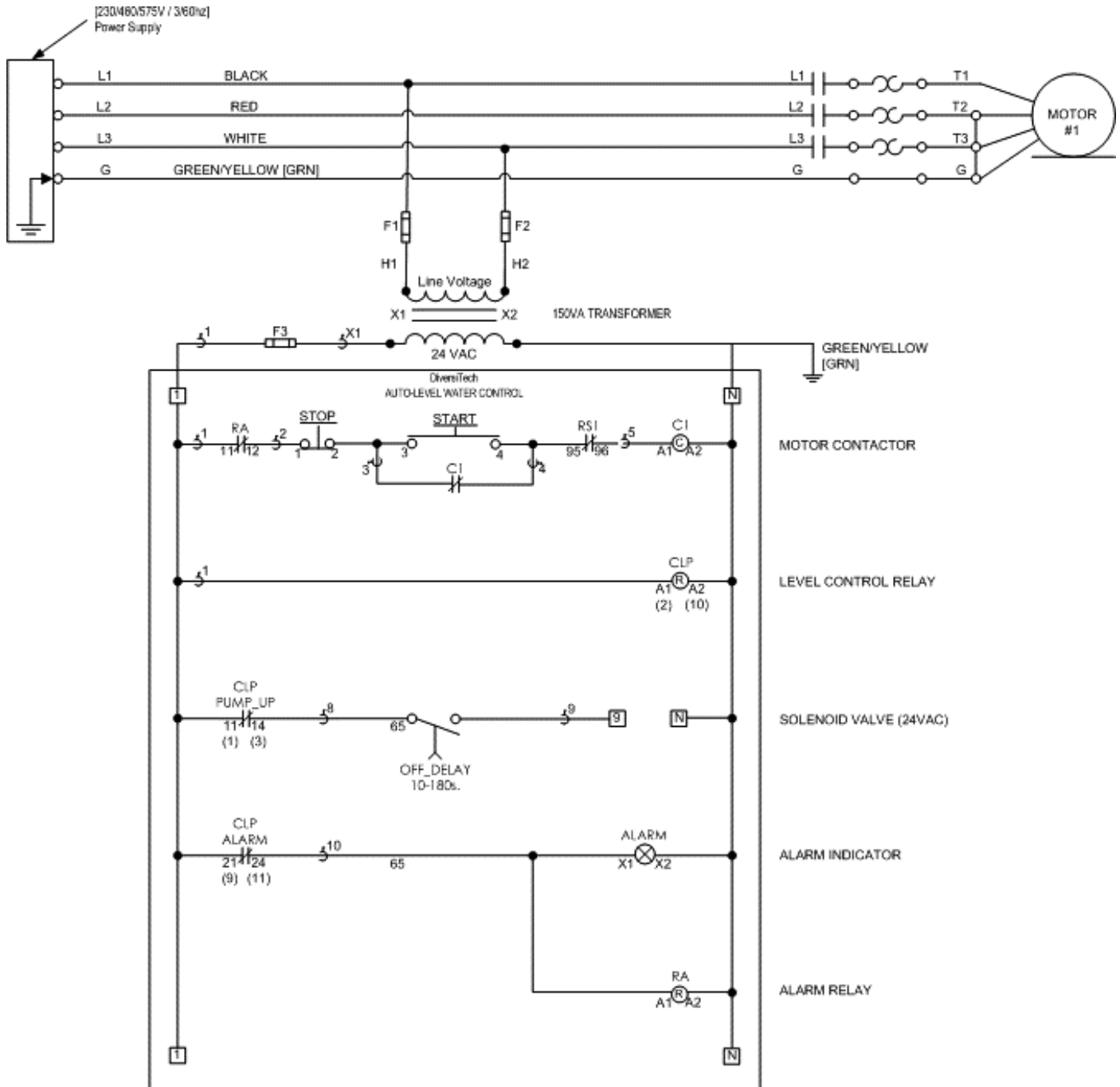

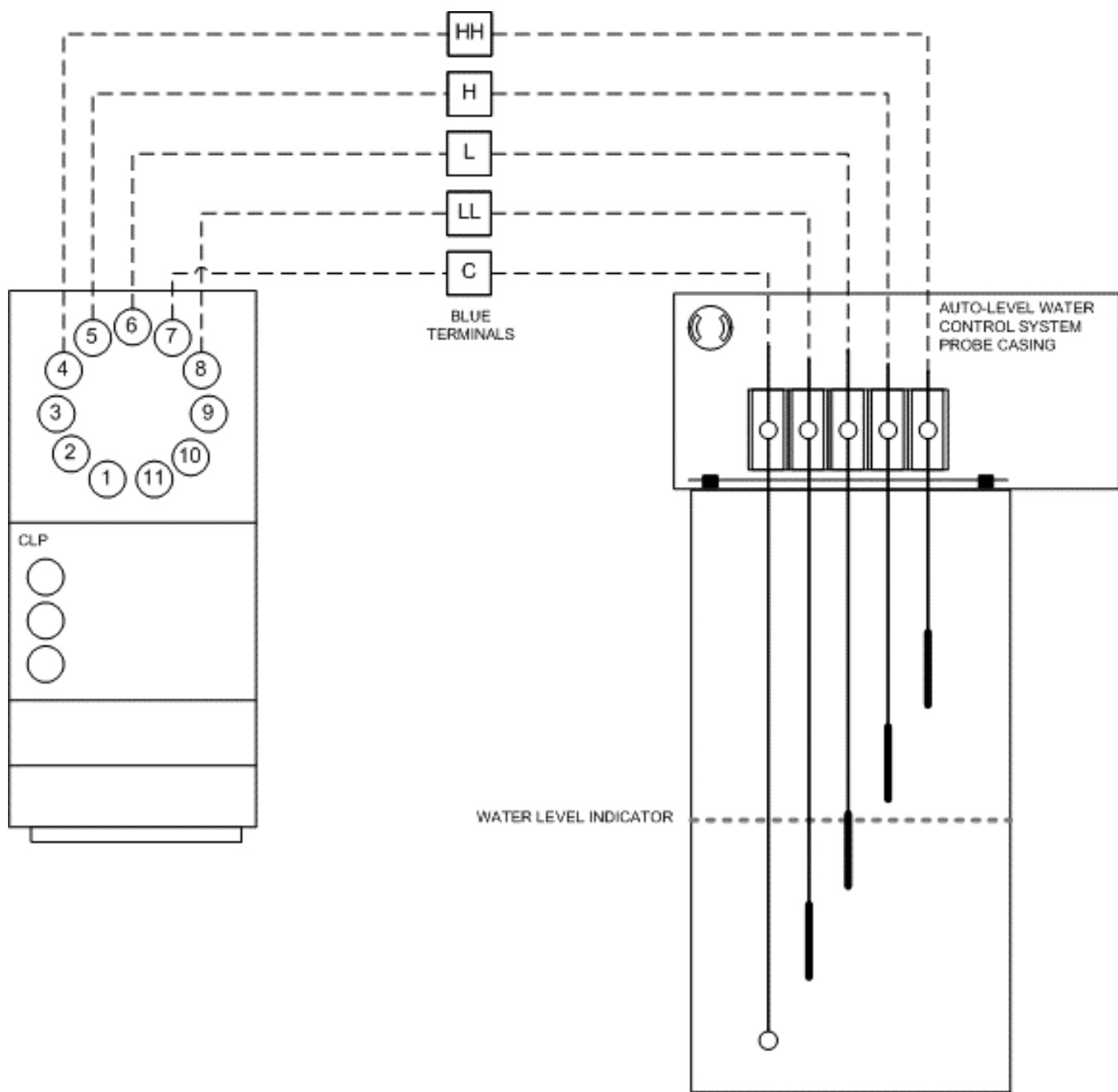

APPENDIX 2 - OPTIONAL AUTO WASH-DOWN SPRAY SYSTEM

Installation

Prime Pump

If the unit is equipped with a water wash system, the water pump may need priming. To prime the pump, remove the plug on the vertical pipe of the pump and fill the pump with sufficient water (up to the top of the pipe fitting) Reinstall the plug

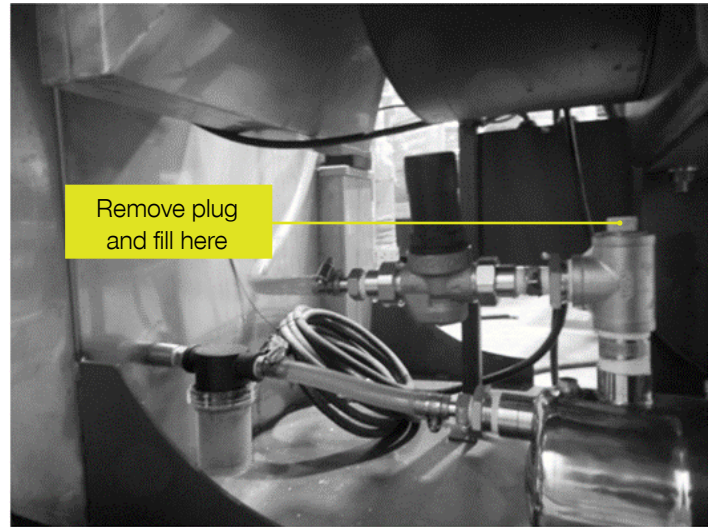

Routine Maintenance Schedule

Optional – Auto Wash-down Spray Kit

Every (1) Week or 15 operating hours – Inspect Pre-filter & Spray Nozzles

1. Inspect the water pumps pre-filter screen, visible through transparent casing, and clean with warm water and mild detergent as required.
2. Turn Auto Wash-down Spray Pump on, and inspect nozzles for clogs. Clean nozzles as required.

LIMITED EQUIPMENT WARRANTY

For a period of 2 years from the date of purchase, all Diversitech products are warranted to be free from defects in material, workmanship, and construction, when used in accordance with installation, maintenance instructions, and expressly stated proper use application(s). Diversitech Inc. will repair or replace, at our option, any defective parts which fail during the warranty period. This warranty is limited to replacement parts ONLY, and does not cover personal liability, property loss, normal wear; and does not cover losses resulting from (or due to) improper installation, inadequate maintenance, misapplication, misuse, or use above rated capacities.

FREIGHT CLAIMS

Shipments must be inspected upon arrival. All Diversitech units are sold ex-plant. Therefore, it is the receiver's responsibility to file any freight claims with the carrier for obvious or concealed damages. Damaged shipments must be refused at time of receipt, by consignee.

RETURN MATERIAL POLICY

Prior to the return of material, for whatever reason, a return manufacturing authorization number (RMA#) is required from the Diversitech customer service department. This procedure is necessary for proper control and handling of returned materials. Call 1-800-361-3733 or email support@diversitech.ca to obtain an RMA.

All material must be returned prepaid. Credit will be given for returns for warranty repair or replacement. Freight collect shipments, or freight without an RMA, will not be accepted. It is the shipper's responsibility to ensure that material being returned to Diversitech is adequately packaged for shipment to preclude damages.



Visit our Website for more
information on this product
www.diversitech.ca

1200 55th Avenue
Montreal, Quebec H8T 3J8
Email: info@diversitech.ca